

Liner Stripper

Operator's Manual

Model 1050

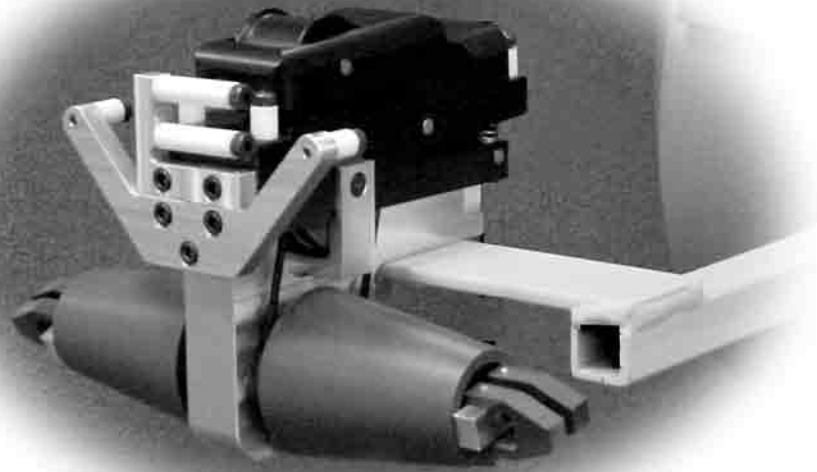

Liner Stripper Operator's Manual Index

Loading the Liner Stripper	3
Starting the Liner Removal	3
Left Side Liner Routing	4
Right Side Liner Routing	5
Operating the Liner Stripper	6
Maintenance	7
Troubleshooting Tips	8
Parts Diagram	10
Additional Notes	11

Liner Stripper Loading and Starting

Loading the liner stripper

1. Push down on the rear of the top body, lifting the pressure roller clear of the drive wheel.
2. Insert the spacer (silver side up) into the back opening formed by the top and main body and between the rear guide rollers.
3. Continue to push the spacer toward the front of the stripper, over the drive wheel and out through the front rollers. (Hint: If the spacer is curled and tries to catch in front of the drive wheel, twist the spacer as you push it through.)

No adjustments are required to compensate for different spacer widths or thicknesses.

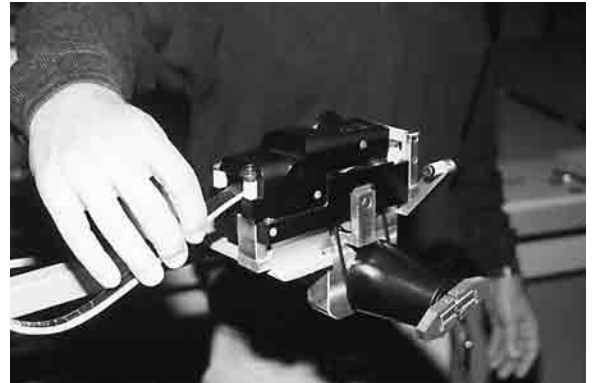

Starting the liner removal

After loading the liner stripper, pull approximately 24 inches through the unit to allow easy access for gripping the liner so it can be prepared for removal.



Left Side Liner Routing

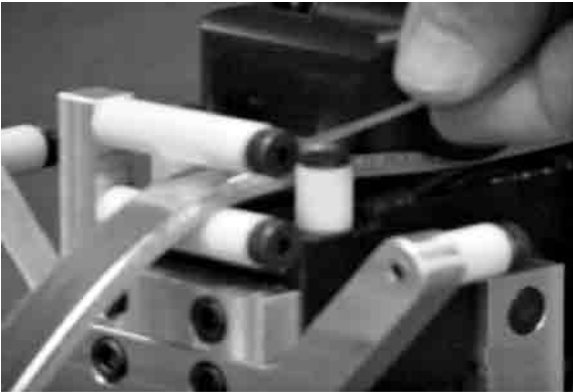

1. Pull the left side liner free up to the front rollers and route it between the top and bottom front rollers as shown.

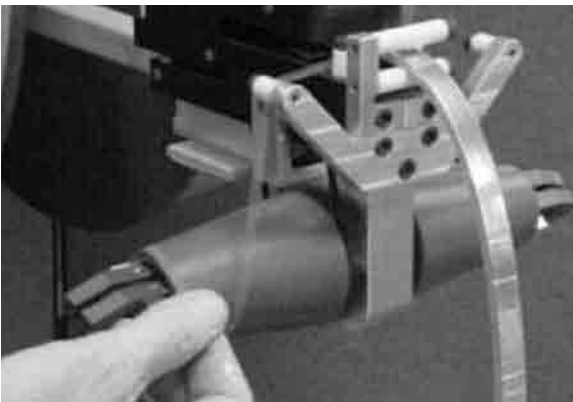

2. Pull the liner to the left hand side of the liner stripper, routing it in front of the left guide roller and over the left front wing roller.



3. Pull the liner straight down from the front wing roller and wrap it around the driven cone in a clockwise direction several times.
4. Snap one of the cone retainer wings over the liner to hold it in position. Snap the remaining retainer wing closed.

Right Side Liner Routing

1. Pull the right side liner free up through the front rollers, routing it around the front of the right guide roller.
2. Pull the liner to the right side of the liner stripper, over the right front wing roller and straight down to the front side of the right driven cone.
3. Wrap the liner around the driven cone in a counter-clockwise direction several times, and secure it with one of the cone retainer wings as done on the left side.
4. Snap the remaining cone retainer wing closed.

NOTE: As the liner is stripped from the spacer, it is possible for a small amount of adhesive residue to remain on the liner. To minimize the possibilities of adhesive build-up on the rollers and cones, route the liner with the adhesive contact side to the outside of the contact surfaces.

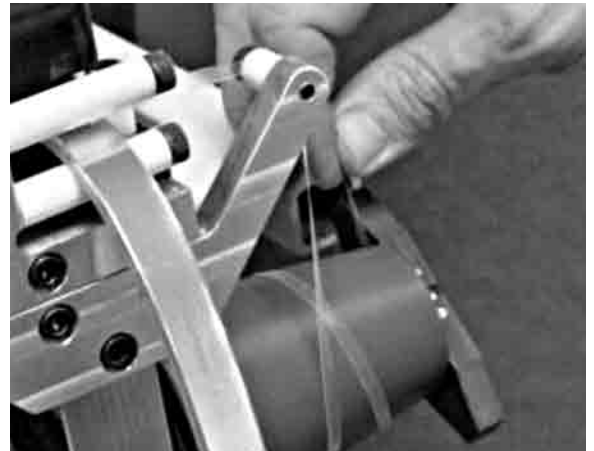
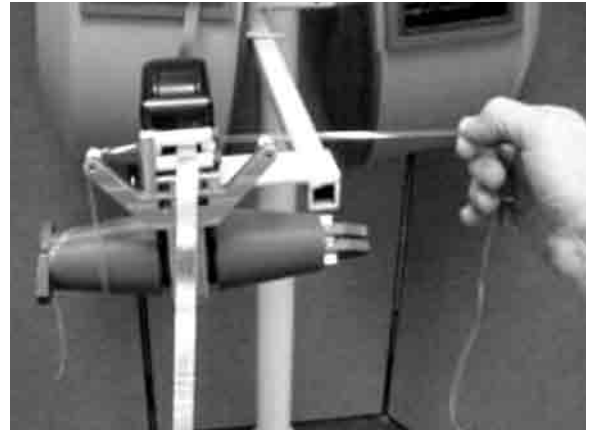

Operating the Liner Stripper

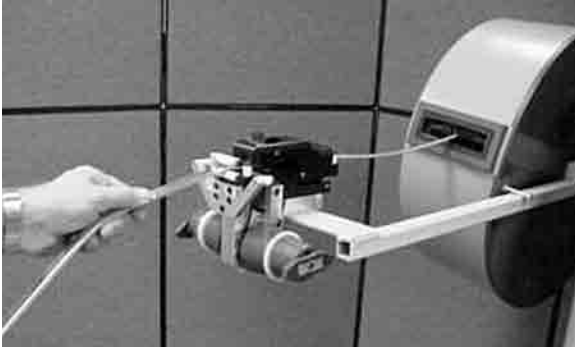

Pulling spacer through stripper

1. Pull the spacer as necessary for application.
The liner will begin to spool on the driven cones.



Driven cones filling with liner

2. As spacer is used, the driven cones will continue to fill, with the retainer wings keeping the liner in place until it is necessary to remove and discard it.



Removing the liner from cones

3. To remove the liner, first open the cone retainer wings, then remove the liner from the driven cone and discard. The liner can become quite tightly wound. Using both hands as shown will easily remove it from the tapered driven cone.

NOTE: Maximum capacity of the liner stripper is approximately 800 ft. of liner. It is more probable that you will want to remove and discard the liner before completely full.



Maintenance

See page 10 for Parts Diagram

Removing the front body screw

1. Maintenance operations such as drive belt replacement are easily accomplished by removing the lower front hex cap screw and pivoting the top body up and out of the way.

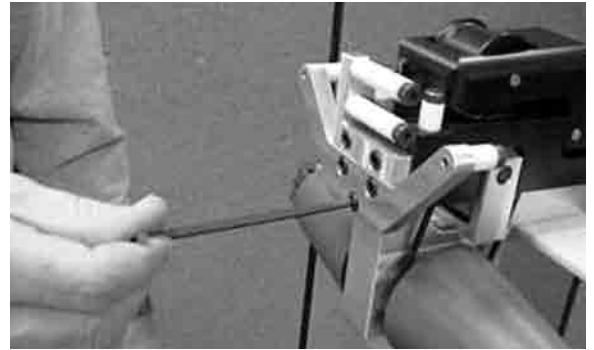

Open the top for maintenance



Replacing the drive belts

NOTE: Keep the surfaces of the cones (item 4) and the rollers (items 11, 14) clean and free of adhesive build-up by wiping occasionally with isopropyl or denatured alcohol or window cleaner.

The rollers (items 11, 14) should rotate freely. If after time they begin to get sluggish, remove the shoulder screw (items 21, 22) and remove any debris that has built up on the teflon rollers.



Troubleshooting Tips

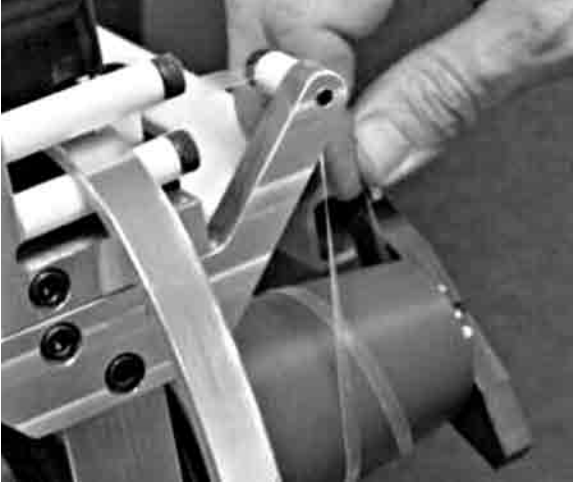

- 1. On start-up with empty cones, the liner isn't taken up correctly and stays on the spacer as it passes through the front rollers.**
 - a. Be sure to wrap the liner around the cones (item 4) several times in the correct direction (see pages 4 & 5).
 - b. The liner must pass over the front wing rollers (item 5) and down to the front of the cone (item 4) to obtain the correct drive ratio.
 - c. Check the movement of the top body (item 1). It should move freely when pressing down on the back of the liner stripper with moderate spring tension offering resistance. If movement is not free, the spacer may be slipping past the drive wheel (item 15). If necessary, blow out the area between the top body (item 1) and main body (item 2) with compressed air, especially around the clamp springs (item 28), until free movement is regained.
 - d. The friction drum may have lost its adhesion to the drive wheel (item 15). If this occurs, it can be resecured with super glue.
 - e. The drive belts (item 29) may be slipping excessively. Remove the belts and clean with isopropyl or denatured alcohol or glass cleaner. If the belts are stretched or dried out, replace them.

Troubleshooting Tips

2. The liner is difficult to remove from the cones when they are full.

- a. Make sure to remove any adhesive build-up on the cones (item 4).
- b. Remove the liner before the cones become excessively full. As the removal continues, the wraps become tighter as the diameter increases. It will take less time to remove the liner several times per reel than to try and remove it once at the end of each reel.
- c. Use both hands as shown when removing the spacer.

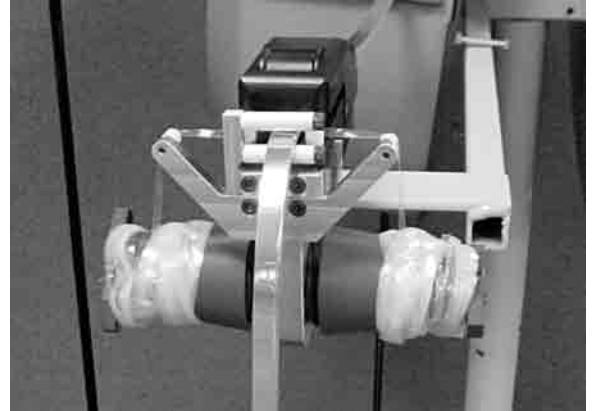

Parts Diagram

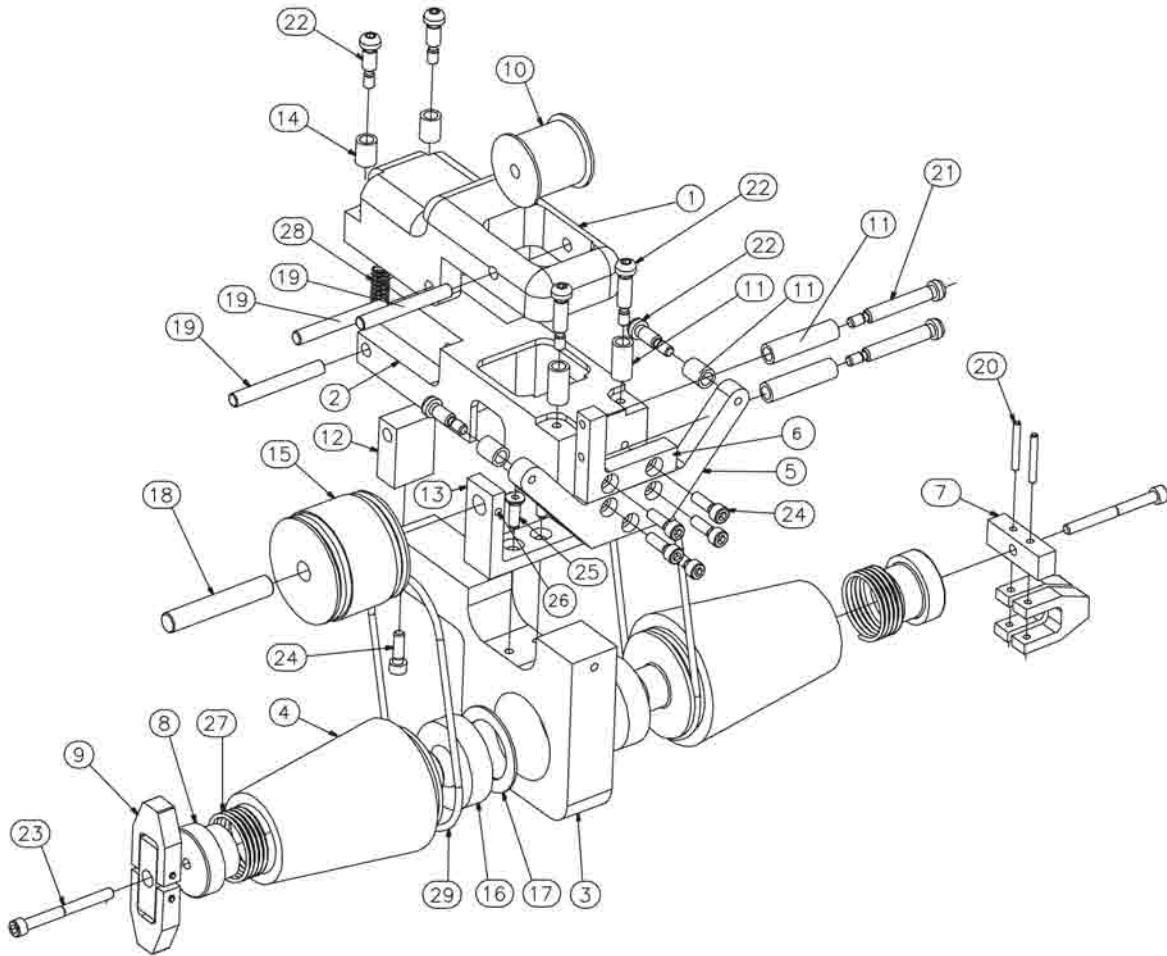

Item	Qty.	Part No.	Description
1	1	E-1050 1000	BODY, TOP
2	1	E-1050 1001	BODY, MAIN
3	1	E-1050 1002	BRACKET, BOTTOM
4	2	E-1050 1003	CONE, DRIVEN
5	1	E-1050 1004	BRACKET, SHORT ROLLER
6	1	E-1050 1005	BRACKET, LONG ROLLER
7	2	E-1050 1006	BRACKET, CONE WING
8	2	E-1050 1007	BUTTON, CONE SPRING
9	4	E-1050 1008	WING, CONE
10	1	E-1050 1009	ROLLER, PRESSURE
11	2	E-1050 1011	ROLLER, LONG
12	1	E-1050 1013	PIVOT, REAR
13	1	E-1050 1014	BRACKET, DRIVE WHEEL
14	6	E-1050 1015	ROLLER, SHORT
15	1	E-1050 5100	WHEEL, DRIVE

Item	Qty.	Part No.	Description
16	2	E-9900 0002	BEARING, 20 x 42 x 12mm
17	1	E-9980 0005	SHIM, STEEL
18	1	E-9980 0006	PIN, DOWEL, 3/8 x 2-1/4
19	3	E-9980 0007	PIN, DOWEL 1/4 x 2
20	4	E-9980 0008	PIN, DOWEL 1/8 x 1
21	2	E-9980 0009	SCREW, SHOULDER 1/4 x 1-1/2
22	6	E-9980 0010	SCREW, SHOULDER 1/4 x 3/4
23	2	E-9980 0012	SCREW, SHC 10-24 x 2
24	6	E-9980 0013	SCREW, SHC 10-24 x 5/8
25	2	E-9980 0014	SCREW, FHC 10-24 x 5/8
26	1	E-9980 0015	SCREW, SET 8-32 x 3/16
27	2	E-9980 0016	SPRING, SNAP
28	2	E-9980 0017	SPRING, CLAMP
29	2	E-9980 0018	BELT, 3-1/4 ID x 3-1/2 OD x 1/8

Additional Notes

Liner Stripper QA Check List

Serial # _____

Date _____

Customer _____

Order # _____

Check Points	QA #1	Comments
Tighten Screws	<input type="checkbox"/>	_____
White Rollers spin freely	<input type="checkbox"/>	_____
Pressure Roller moves freely	<input type="checkbox"/>	_____
Top Body clamps freely	<input type="checkbox"/>	_____
Drive Wheel rotates Driven Cones	<input type="checkbox"/>	_____
Drive Belts clear all body parts	<input type="checkbox"/>	_____
Strips Liner off of spacer(repeated twice)	<input type="checkbox"/>	_____

QA Signature #1 _____



We're there for you at every turn! 

800 Cochran Avenue • Cambridge, Ohio 43725
740-439-2338 • www.superspacer.com

rev. 02/2010